

WORD 2016 ESSENTIALS TRAINING
1 DAY, \$373.00

 BRING YOUR OWN LAPTOP®

COURSE OVERVIEW

You know Microsoft Word. Except for a couple of features. Oh, and all the features you didn't know existed. And, of course, all those tools that don't seem to behave predictably. You get the idea. Often a limited knowledge isn't making the most of what Word, or you, are capable of.

What if you could have a course without the droning lectures? What if your Microsoft Word training didn't require several textbooks and strong coffee?

The BYOL Word Essentials training is hands on and based around creating typical workplace projects. You start with basic document production & editing. You'll have all the essentials covered. Then you can master more advanced workflow techniques like paragraph styles, tables, macros & mail merge.

Bring your own familiar laptop to work from or we'll supply one free of charge. Mac or PC, in the same class.



Your Word course is led by an in-

structor whose skills are not just in Microsoft Office products, but in making it understandable for you. You get the help at every step. "No one left behind" is something we take seriously.

We continue to help you after your class with 12-months email support. And if there is any concept or idea that you haven't fully understood we invite you to repeat the course within 12 months completely free.

To be even more helpful, Bring Your Own Laptop gives you exclusive video tutorials that cover every aspect of your training. No other course provider in the country offers this level of in-class and after class support.

We help you at every step, and well after the course, to give you the skills and experience you need to master Microsoft Word.

CLASS PROJECTS

1. Creating a formal business letter
2. Creating a monthly company newsletter
3. Formatting a long business report adding charts & graphs from Excel
4. Creating a timetable schedule using tables
5. Creating a company template using corporate fonts, colours & images
6. Creating a product overview PDF with basic in interactivity
7. Creating a business form
8. Printing personalized letterheads & envelopes for client lists.



WHO SHOULD ATTEND

If you have little or no previous experience in Microsoft Word this course is for you. We'll start right at the basics and work step by step through our projects so no one is left behind. By the end of the course we'll be working with the more advanced features of Word to ensure everyone gets the understanding and value they're looking for.

This is a relaxed, well-paced course for people new to Word. Only basic computing skills are necessary - If you can send emails and surf the internet then you'll be fine with our course.

MORE COURSE INFORMATION

A lot of people use Microsoft Word. It's the cornerstone of the Microsoft Office suite, and it's one of those basics on everyone's CV. But not many people 'know' Word. There's a lot in there, and often not a lot of knowledgeable help beyond typing and spell check.

At Bring Your Own Laptop, we've spent years teaching people at every level some pretty sophisticated software. So, when we decided to make our Microsoft Word training even better, we started from the other end. Support.

We know we have great training, but we've learned over the years that many of your questions come well after you've attended one our

Additional Courses	1 Day	2 Day
Microsoft Word	\$373	\$597
Microsoft Excel	\$373	\$597
Microsoft Powerpoint	\$373	\$597
Microsoft Access	\$473	\$747
Microsoft Project	\$473	\$747

courses. You can't remember everything in one day. While our hands on directed learning is a great way to learn something, we don't expect you to memorize every detail. That's why we provide you with videos of every single aspect of your course. We also provide free email support for any Word related questions you might have. And if that wasn't enough, and you don't think you got it the first time, we offer you a completely free resit of the course within 12 months! On top of all of that, we'll present you with a certificate to add more weight to your CV. Our classroom training is so interactive, it's all the attention of a one on one coaching session, but with classmates who will ask the questions you didn't know to ask. We make sure you understand as you go, with help at every step.

WORD

BOOTCAMP

 BRING YOUR OWN LAPTOP®

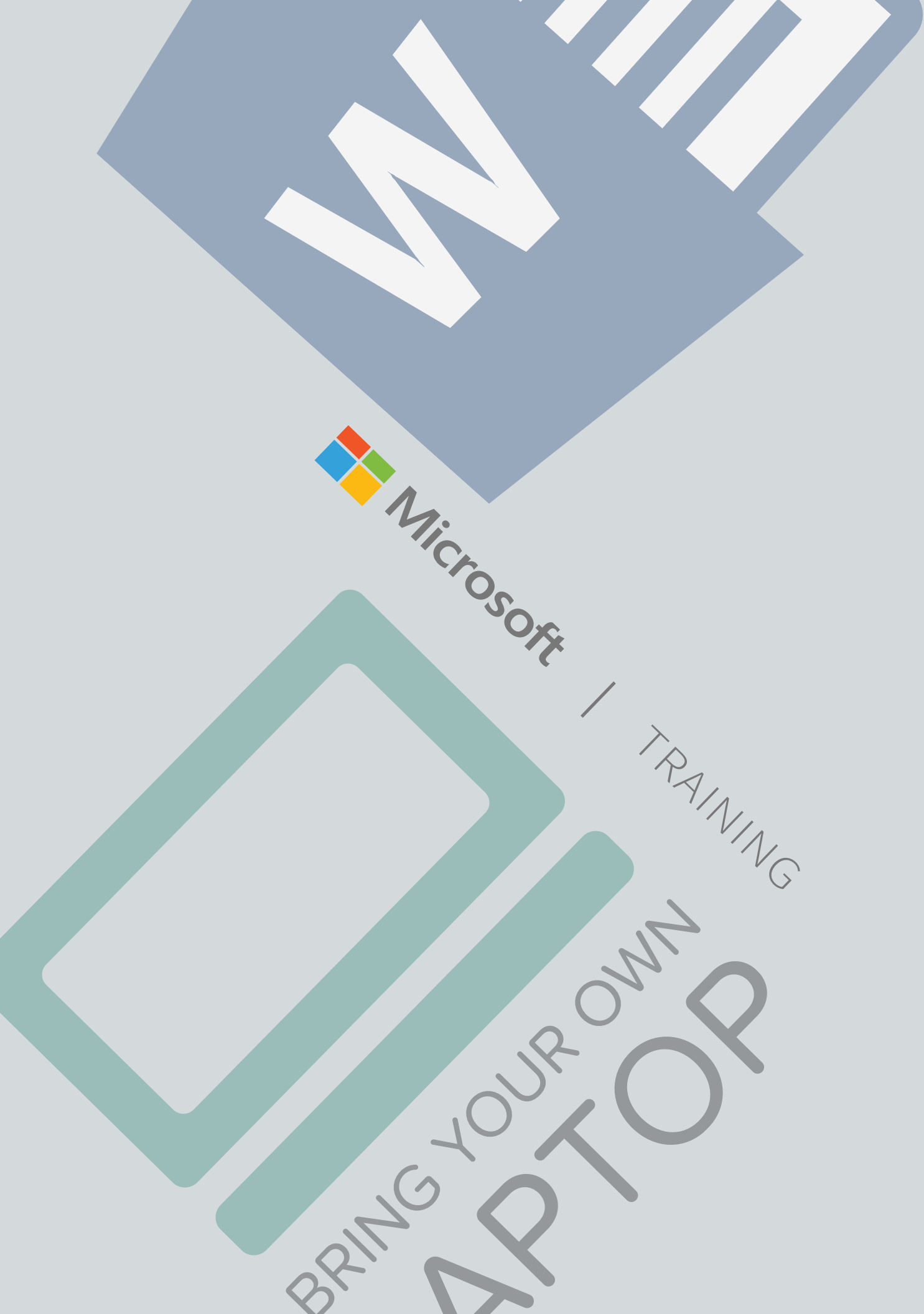



ORANGE CRUSH

smoothie



Advanced Voice Control

It integrated the newest smart technology to allow the voice answer the call, once the call coming, just say "YES" will answer the call, say "NO" will reject the call.

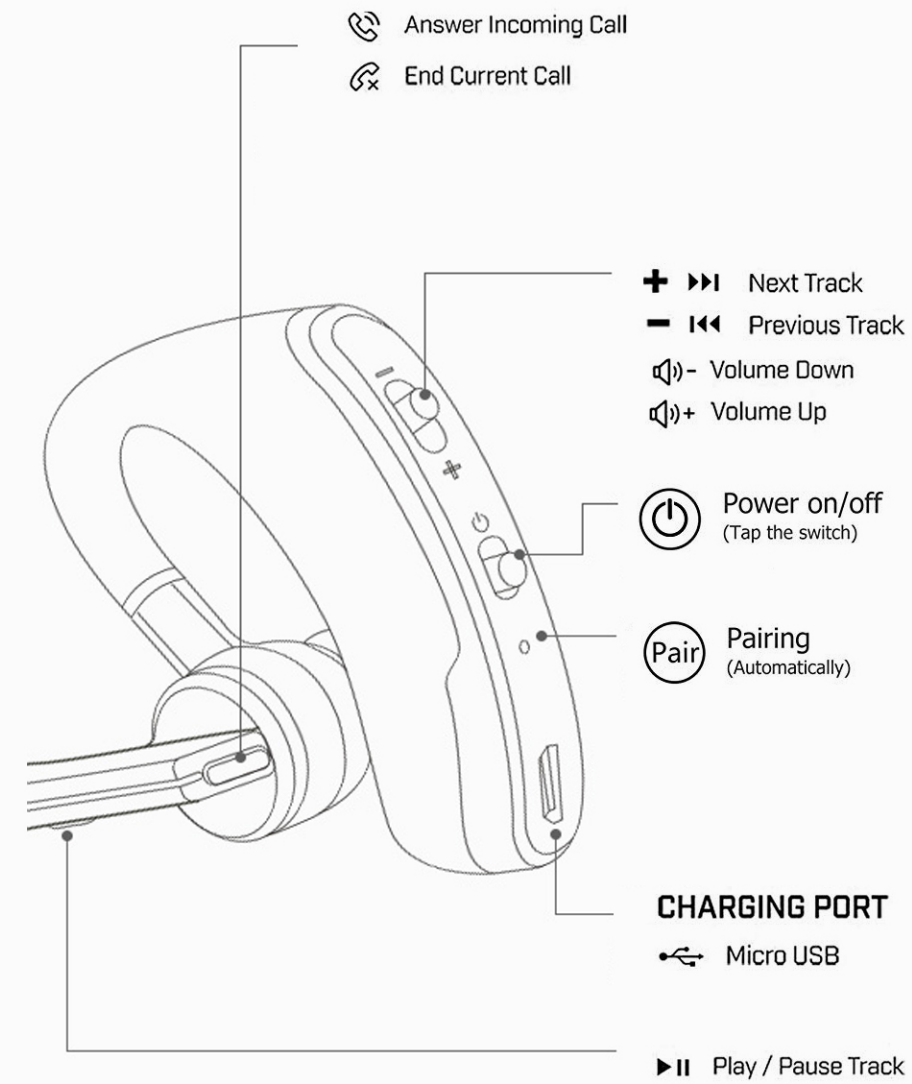



The ear plug can rotate 180 degrees.



The arm can rotate 270 degrees.

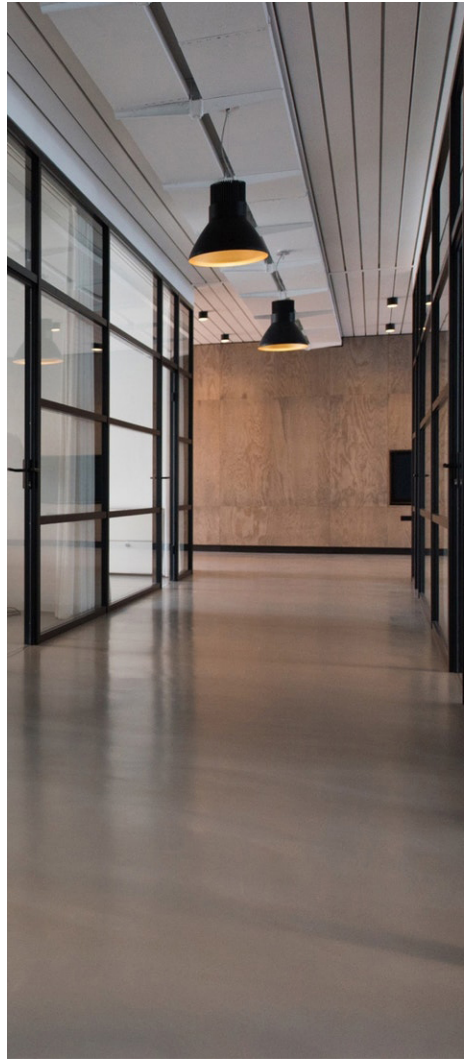

Charging Port

Power Indicator

Red light is up when charging.

Power ON/OFF

Lightly tap the switch.

Headset Power Indicator

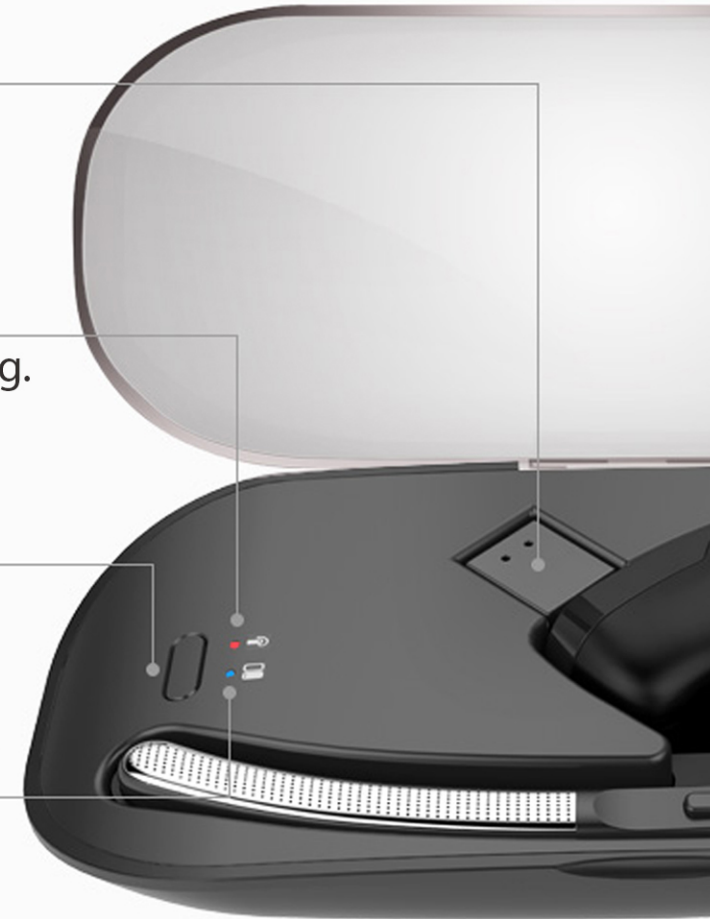

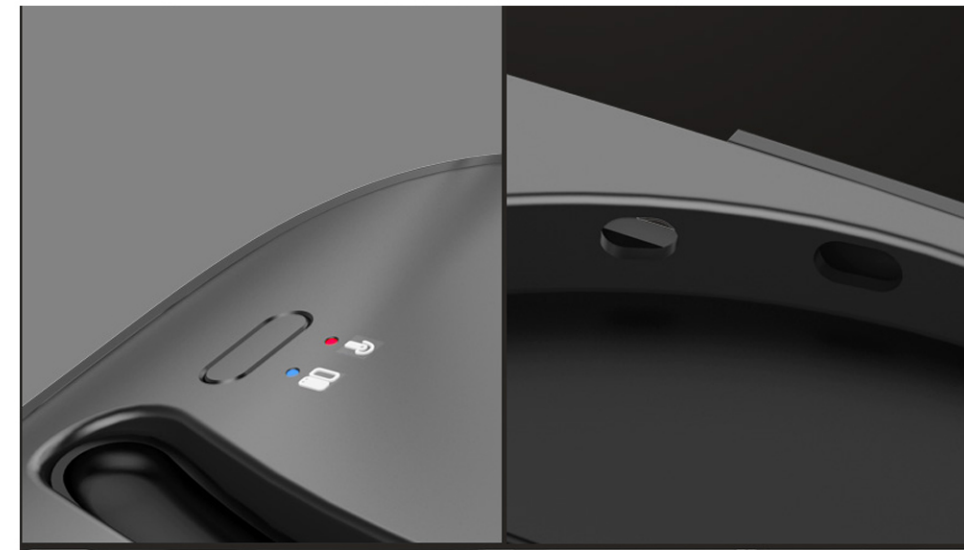
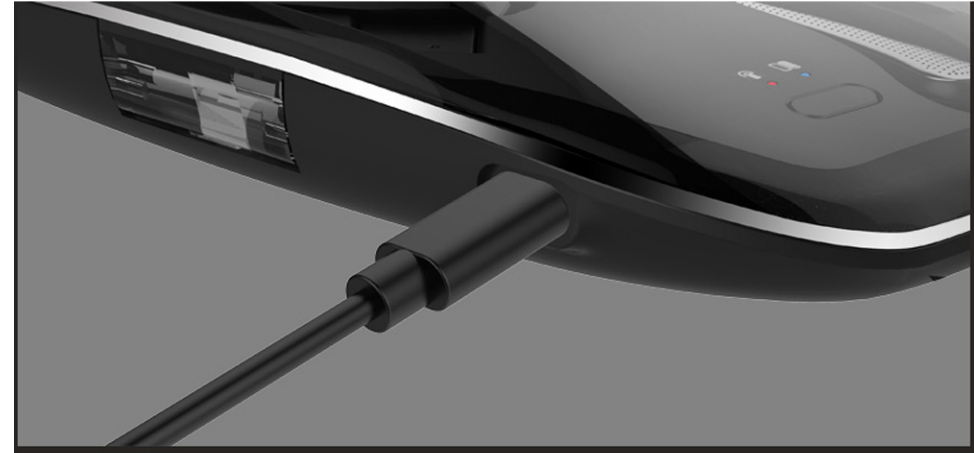
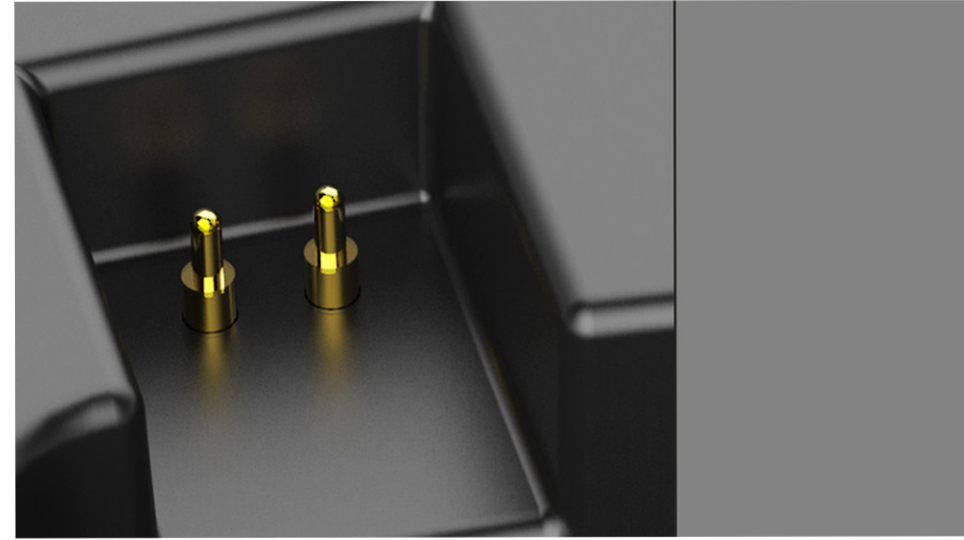



10 meters strong
signal cover the whole office.







THE PACKAGE WILL INCLUDE

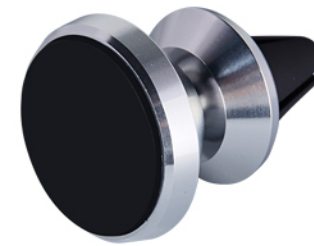



① *Prepare your package.*



② *Clean the surface using the cleaning wipe.*



③ *Attach the protective sheet to the center of the phone.*



④ *Stick the magnet sheet to the center of the film on the phone.*



20X
Magnetic
power

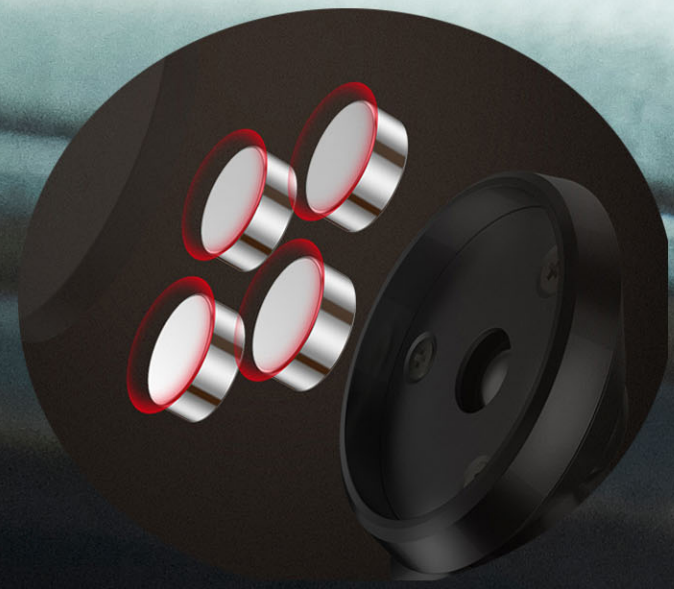



Compact and Elegant





① *Prepare your package.*



② *Clean the surface using the cleaning wipe.*



③ *Attach the protective sheet to the center of the phone.*



④ *Stick the magnet sheet to the center of the film on the phone.*



Simple design
only for
easy to carry.

Charging
anywhere, anytime.





Dont judge from outside.



Start a family?



It is ok to be different.